

SECTION **RAX**
REAR AXLE

A
B
C

RAX

CONTENTS

E

SYMPTOM DIAGNOSIS	2	Inspection	6	F
NOISE, VIBRATION AND HARSHNESS (NVH) TROUBLESHOOTING	2	REMOVAL AND INSTALLATION	7	
NVH Troubleshooting Chart	2	REAR WHEEL HUB AND HOUSING	7	G
PRECAUTION	3	Exploded View	7	
PRECAUTIONS	3	Removal and Installation	7	
Precautions for Drive Shaft	3	Inspection	9	H
PREPARATION	4	REAR DRIVE SHAFT	10	
Special Service Tool	4	Exploded View	10	I
Commercial Service Tool	4	Removal and Installation	10	
PERIODIC MAINTENANCE	5	Disassembly and Assembly	11	J
REAR WHEEL HUB AND HOUSING	5	Inspection	15	
Inspection	5	SERVICE DATA AND SPECIFICATIONS (SDS)	16	K
REAR DRIVE SHAFT	6	SERVICE DATA AND SPECIFICATIONS (SDS)	16	L
		Wheel Bearing	16	
		Drive Shaft	16	

F

G

H

I

J

K

L

M

N

O

P

NOISE, VIBRATION AND HARSHNESS (NVH) TROUBLESHOOTING

< SYMPTOM DIAGNOSIS >

SYMPTOM DIAGNOSIS

NOISE, VIBRATION AND HARSHNESS (NVH) TROUBLESHOOTING

NVH Troubleshooting Chart

INFOID:000000001907755

Use chart below to find the cause of the symptom. If necessary, repair or replace these parts.

Reference page			Possible cause and SUSPECTED PARTS														
			Excessive joint angle	Joint sliding resistance	Imbalance	Improper installation, looseness	Parts interference	PROPELLER SHAFT	DIFFERENTIAL	REAR AXLE AND REAR SUSPENSION	REAR AXLE	TIRE	ROAD WHEEL	DRIVE SHAFT	BRAKE	STEERING	
Symptom	DRIVE SHAFT	Noise	x	x				x	x	x	x	x	x		x	x	
		Shake	x		x			x		x	x	x	x		x	x	
	REAR AXLE	Noise				x	x	x	x	x		x	x	x	x	x	x
		Shake				x	x	x		x		x	x	x		x	x
		Vibration				x	x	x		x		x		x			x
		Shimmy				x	x			x		x	x			x	x
		Judder				x				x		x	x			x	x
		Poor quality ride or handling				x	x			x		x	x				
	Reference page			—	RAX-15	—	RAX-7	—	NVH in DLN section.	NVH in DLN section.	NVH in RAX and RSU sections.	Refer to REAR AXLE in this chart.	NVH in WT section.	NVH in WT section.	Refer to DRIVE SHAFT in this chart.	NVH in BR section.	NVH in ST section.

x: Applicable

PRECAUTIONS

< PRECAUTION >

PRECAUTION

PRECAUTIONS

Precautions for Drive Shaft

INFOID:0000000001907756

Observe the following precautions when disassembling and assembling drive shaft.

- Joint sub-assembly never disassemble because it is non-overhaul parts.
- Perform work in a location which is as dust-free as possible.
- Before disassembling and assembling, clean the outside of parts.
- Disassembled parts must be carefully reassembled in the correct order. If work is interrupted, a clean cover must be placed over parts.
- Paper waste must be used. Fabric shop cloths must not be used because of the danger of lint adhering to parts.
- Disassembled parts (except for rubber parts) should be cleaned with kerosene which shall be removed by blowing with air or wiping with paper waste.

A

B

C

RAX

E

F

G

H

I

J

K

L

M

N

O

P

PREPARATION

< PREPARATION >

PREPARATION

PREPARATION

Special Service Tool

INFOID:000000001907757

The actual shapes of Kent-Moore tools may differ from those of special service tools illustrated here.

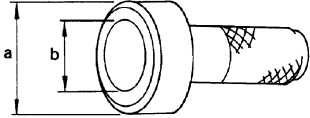
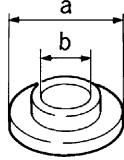
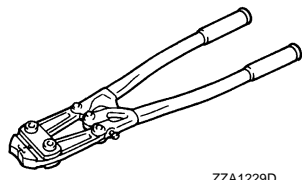
Tool number (Kent-Moore No.) Tool name		Description
KV38100500 (-) Drift a: 80 mm (3.15 in) dia. b: 60 mm (2.36 in) dia.	 <p style="text-align: center; font-size: small;">ZZA0701D</p>	Installing drive shaft plug
KV38102200 (-) Drift a: 90 mm (3.54 in) dia. b: 31 mm (1.22 in) dia.	 <p style="text-align: center; font-size: small;">ZZA0920D</p>	Installing drive shaft plug
KV40107300 (-) Boot band crimping tool	 <p style="text-align: center; font-size: small;">ZZA1229D</p>	Installing boot band

Commercial Service Tool

INFOID:000000001907758

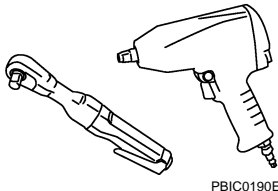
Tool name		Description
Power tool	 <p style="text-align: center; font-size: small;">PBIC0190E</p>	Loosening bolts and nuts

REAR WHEEL HUB AND HOUSING

< PERIODIC MAINTENANCE >

PERIODIC MAINTENANCE

REAR WHEEL HUB AND HOUSING

Inspection

INFOID:000000001907759

MOUNTING INSPECTION

Make sure the mounting conditions (looseness, back lash) of each component and component conditions (wear, damage) are normal.

WHEEL BEARING INSPECTION

- Move wheel hub and bearing assembly in the axial direction by hand. Make sure there is no looseness of wheel bearing.

Standard

Axial end play : Refer to [RAX-16, "Wheel Bearing"](#).

- Rotate wheel hub and bearing assembly and make sure that is no unusual noise or other irregular conditions. If there is any of irregular conditions, replace wheel hub and bearing assembly.

A
B
C
RAX
E
F
G
H
I
J
K
L
M
N
O
P

REAR DRIVE SHAFT

< PERIODIC MAINTENANCE >

REAR DRIVE SHAFT

Inspection

INFOID:000000001907760

- Check drive shaft mounting point and joint for looseness and other damage.
- Check boot for cracks and other damage.

CAUTION:

Replace entire drive shaft assembly when noise or vibration occurs from drive shaft.

REAR WHEEL HUB AND HOUSING

< REMOVAL AND INSTALLATION >

REMOVAL AND INSTALLATION

REAR WHEEL HUB AND HOUSING

Exploded View

INFOID:000000001907761

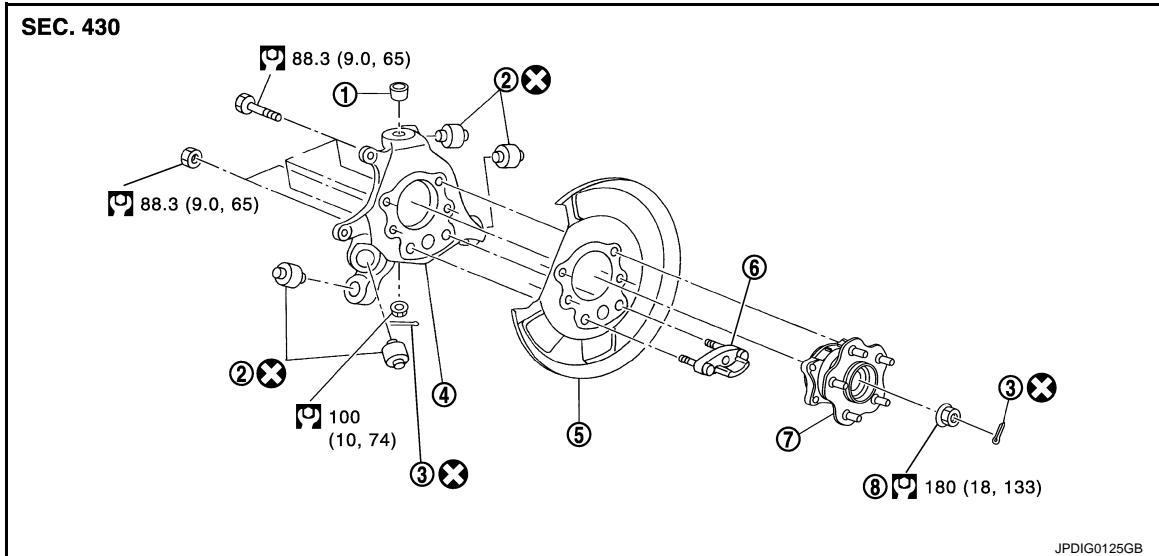

- | | | |
|-----------------------------------|-----------------------|-----------------|
| 1. Ball seat | 2. Bushing | 3. Cotter pin |
| 4. Axle housing | 5. Back plate | 6. Anchor block |
| 7. Wheel hub and bearing assembly | 8. Wheel hub lock nut | |

Refer to [GI-4, "Components"](#) for symbols in the figure.

Removal and Installation

INFOID:000000001907762

REMOVAL

Wheel Hub and Bearing Assembly

1. Remove tire with power tool.
2. Remove caliper assembly. Hang caliper assembly in a place where it will not interfere with work. Refer to [BR-54, "BRAKE CALIPER ASSEMBLY \(FRONT CALIPER 1 PISTON TYPE\) : Exploded View"](#) (front caliper 1 piston type), [BR-58, "BRAKE CALIPER ASSEMBLY \(FRONT CALIPER 2 PISTON TYPE\) : Exploded View"](#) (front caliper 2 piston type).

CAUTION:

Never depress brake pedal while brake caliper is removed.

3. Remove disc rotor. Refer to [BR-54, "BRAKE CALIPER ASSEMBLY \(FRONT CALIPER 1 PISTON TYPE\) : Removal and Installation"](#) (front caliper 1 piston type), [BR-58, "BRAKE CALIPER ASSEMBLY \(FRONT CALIPER 2 PISTON TYPE\) : Removal and Installation"](#) (front caliper 2 piston type).

CAUTION:

- Put matching marks (A) on the wheel hub and bearing assembly and the disc rotor before removing the disc rotor.
- Never drop disc rotor.

4. Remove cotter pin, then loosen wheel hub lock nut with a power tool.

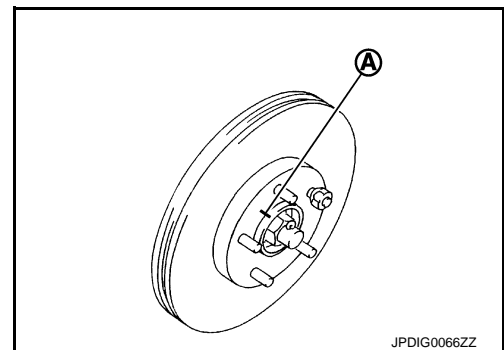

REAR WHEEL HUB AND HOUSING

< REMOVAL AND INSTALLATION >

5. Patch wheel hub lock nut with a piece of wood. Hammer the wood to disengage wheel hub and bearing assembly from drive shaft. Take out the wheel hub lock nut.

CAUTION:

- Never place drive shaft joint at an extreme angle. Also be careful not to overextend slide joint.
- Never allow drive shaft to hang down without support for counterpart such as joint sub-assembly, and other parts.

NOTE:

Use a suitable puller, if the wheel hub and bearing assembly and drive shaft cannot be separated even after performing the above procedure.

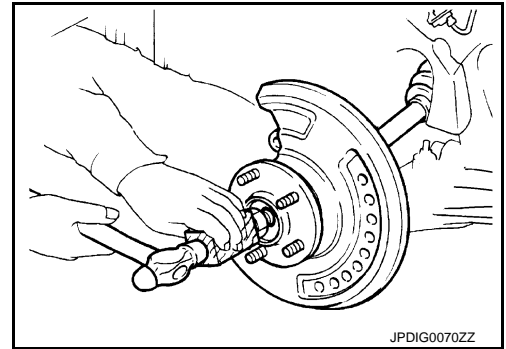

6. Remove cotter pin, then loosen suspension arm mounting nut of axle housing.
7. Remove the wheel hub and bearing assembly.

Axle Housing

1. Remove wheel hub and bearing assembly.
2. Remove parking brake shoe and parking brake cable from back plate. Refer to [PB-9, "Exploded View"](#).
3. Remove mounting nuts in stabilizer side of stabilizer connecting rod with power tool. Refer to [RSU-30, "Exploded View"](#).
4. Remove axle side nuts and bolts on radius rod. Refer to [RSU-22, "Exploded View"](#).
5. Remove coil spring. Refer to [RSU-8, "Exploded View"](#).
6. Set suitable jack under axle housing.
7. Remove mounting bolts and nuts in axle housing side of shock absorber with power tool. Refer to [RSU-12, "Exploded View"](#).
8. Remove axle side nuts and bolts on front lower link, separate front lower link from axle housing. Refer to [RSU-8, "Exploded View"](#).
9. Separate suspension arm from axle housing so as not to damage ball joint boot using ball joint remover, and then remove axle housing from the vehicle.

CAUTION:

 - Temporarily tighten nuts to prevent damage to threads and to prevent the ball joint remover from coming off.
 - Never place drive shaft joint at an extreme angle. Also be careful not to overextend slide joint.
 - Never allow drive shaft to hang down without support for counterpart such as joint sub-assembly, and other parts.
10. Remove anchor block mounting nuts, and then remove anchor block and back plate from axle housing.

INSTALLATION

Note the following, and install in the reverse order of removal.

- Clean the matching surface of wheel hub lock nut and wheel hub and bearing assembly.

CAUTION:

Never apply lubricating oil to these matching surface.

- Clean the matching surface of drive shaft and wheel hub and bearing assembly.

CAUTION:

Apply paste [service parts (440037S000)] to cover entire flat surface (A) of joint sub-assembly of drive shaft.

Standard

Amount paste 1.0 – 3.0 g (0.04 – 0.10 oz)

- Never use a power tool to tighten the wheel hub lock nut.
- Perform the final tightening of each of parts under unladen conditions, which were removed when removing wheel hub and bearing assembly and axle housing.

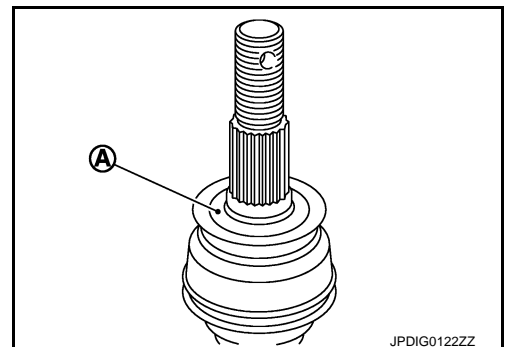

REAR WHEEL HUB AND HOUSING

< REMOVAL AND INSTALLATION >

- Align the matching marks (A) that have been made during removal when reusing the disc rotor.
- Never reuse cotter pin and bushing.

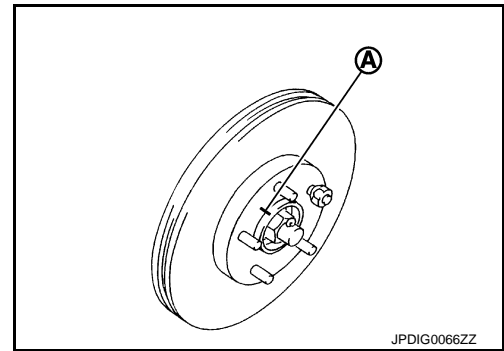

Inspection

INFOID:000000001907763

A
B
C
RAX

INSPECTION AFTER REMOVAL

Wheel Hub and Bearing Assembly

Check the wheel hub and bearing assembly for wear, cracks, and damage. Replace if there are.

Axle Housing

Check the axle housing for wear, cracks, and damage. Replace if there are.

Ball Joint Inspection

Check for boot breakage, axial looseness, and torque of suspension arm ball joint. Refer to [RSU-5, "Inspection and Adjustment"](#).

INSPECTION AFTER INSTALLATION

1. Adjust parking brake operation (stroke). Refer to [PB-3, "PEDAL TYPE : Inspection and Adjustment"](#) (pedal type), [PB-4, "LEVER TYPE : Inspection and Adjustment"](#) (lever type).
2. Check wheel alignment. Refer to [RSU-6, "Inspection"](#).
3. Adjust neutral position of steering angle sensor. Refer to [BRC-8, "ADJUSTMENT OF STEERING ANGLE SENSOR NEUTRAL POSITION : Special Repair Requirement"](#).

E
F
G
H
I
J
K
L
M
N
O
P

REAR DRIVE SHAFT

< REMOVAL AND INSTALLATION >

REAR DRIVE SHAFT

Exploded View

INFOID:000000001907764

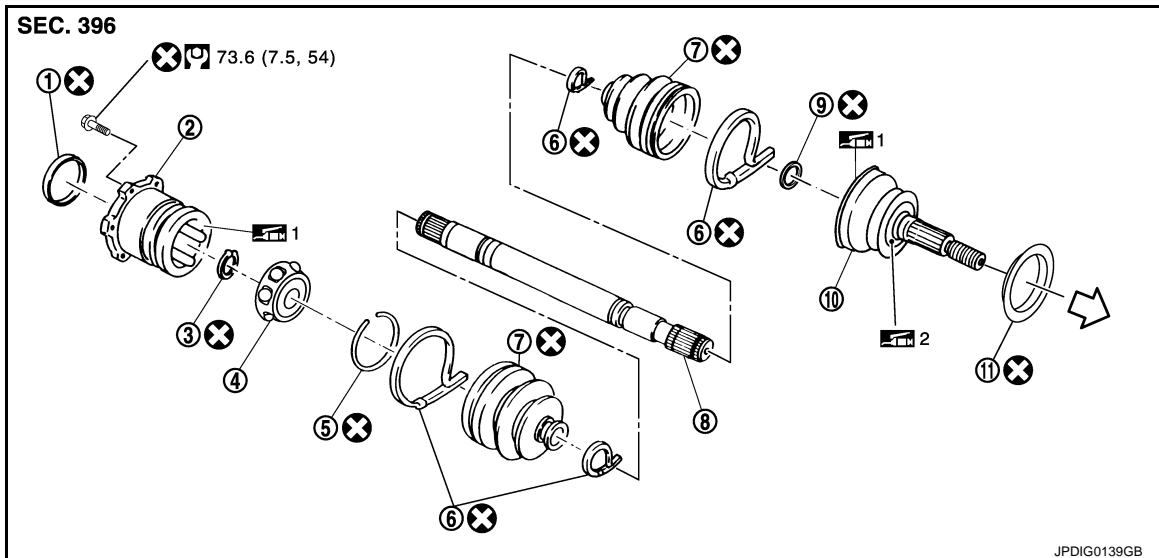

- | | | |
|---|-----------------|------------------|
| 1. Plug | 2. Housing | 3. Snap ring |
| 4. Ball cage/steel ball/inner race assembly | 5. Stopper ring | 6. Boot band |
| 7. Boot | 8. Shaft | 9. Circular clip |
| 10. Joint sub-assembly | 11. Dust shield | |

⇐: Wheel side

1 : NISSAN genuine grease or an equivalent.

2 : Apply paste [service parts (440037S000)].

Refer to [GI-4, "Components"](#) for symbols not described on the above.

Removal and Installation

INFOID:000000001907765

REMOVAL

1. Remove tire with power tool.
2. Remove cotter pin, then loosen wheel hub lock nut with power tool.
3. Remove main muffler and center muffler. Refer to [EX-5, "Exploded View"](#).

4. Patch wheel hub lock nut with a piece of wood. Hammer the wood to disengage wheel hub and bearing assembly from drive shaft. Take out the wheel hub lock nut.

CAUTION:

- Never place drive shaft joint at an extreme angle. Also be careful not to overextend slide joint.
- Never allow drive shaft to hang down without support for counterpart such as joint sub-assembly, and other parts.

NOTE:

Using a suitable puller if the wheel hub and bearing assembly and drive shaft cannot be separated even after performing the above procedure.

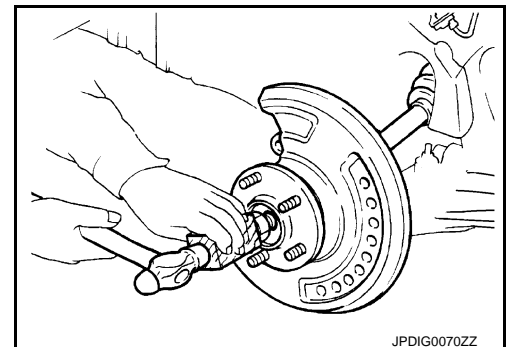

JPDIG0070ZZ

5. Remove mounting bolts between side flange and drive shaft with power tool.

INSTALLATION

Note the following, and install in the reverse order of removal.

- Clean the matching surface of wheel hub lock nut and wheel hub and bearing assembly.

CAUTION:

REAR DRIVE SHAFT

< REMOVAL AND INSTALLATION >

Never apply lubricating oil to these matching surface.

- Clean the matching surface of drive shaft and wheel hub and bearing assembly.

CAUTION:

Apply paste [service parts (440037S000)] to cover entire flat surface (A) of joint sub-assembly of drive shaft.

Standard

Amount paste 1.0 – 3.0 g (0.04 – 0.10 oz)

- Never use a power tool to tighten the wheel hub lock nut.
- Perform the final tightening of each of parts under unladen conditions, which were removed when removing wheel hub and bearing assembly and axle housing.
- Never reuse cotter pin and bushing.

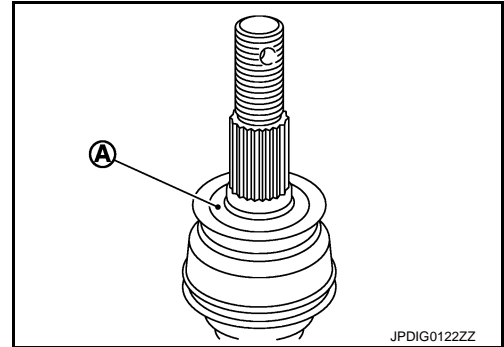

INFOID:000000001907766

Disassembly and Assembly

DISASSEMBLY

Rear Final Drive Side

1. Fix shaft with a vise.

CAUTION:

Protect shaft when fixing with a vise using aluminum or copper plates.

2. Remove boot bands, and then remove boot from housing.
3. If plug needs to be removed, move boot to wheel side, and take it out with a plastic hammer.
4. Put matching marks on housing and shaft.

CAUTION:

Use paint or similar substance for matching marks. Never scratch the surface.

5. Remove stopper ring with suitable tool, and pull out housing.

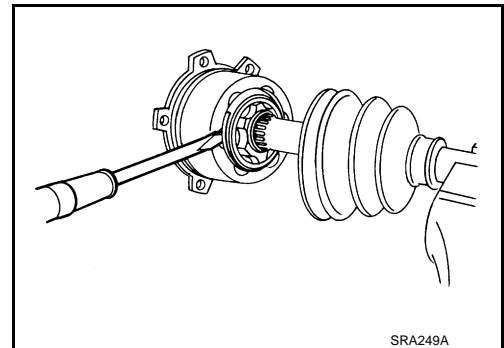

6. Put matching marks on ball cage/steel ball/inner race assembly and shaft.

CAUTION:

Use paint or similar substance for matching marks. Never scratch the surface.

7. Remove snap ring, then remove ball cage/steel ball/inner race assembly from shaft.
8. Remove boot from shaft.
9. Remove old grease on housing with paper waste.

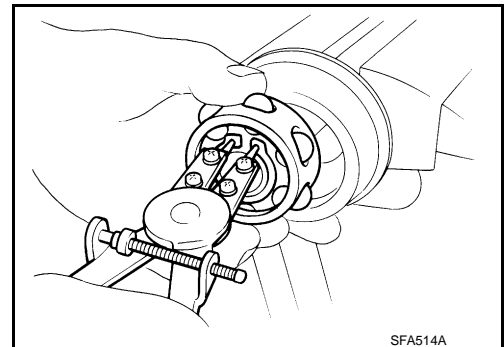

Wheel Side

1. Remove dust shield from drive shaft.
2. Fix shaft with a vise.

CAUTION:

A
B
C
RAX
E
F
G
H
I
J
K
L
M
N
O
P

REAR DRIVE SHAFT

< REMOVAL AND INSTALLATION >

Protect shaft when fixing with a vise using aluminum or copper plates.

- Remove boot bands. Then remove boot from joint sub-assembly.
- Screw the drive shaft puller (A) 30 mm (1.18 in) or more into the thread of joint sub-assembly, and pull joint sub-assembly with a sliding hammer (B) from shaft.

CAUTION:

- If joint sub-assembly cannot be removed after five or more unsuccessful attempts, replace shaft and joint sub-assembly as a set.
- Align sliding hammer and drive shaft and remove them by pulling directory.

- Remove circular clip from shaft.
- Remove boot from shaft.
- While rotating ball cage, clean old grease on joint sub-assembly with paper waste.

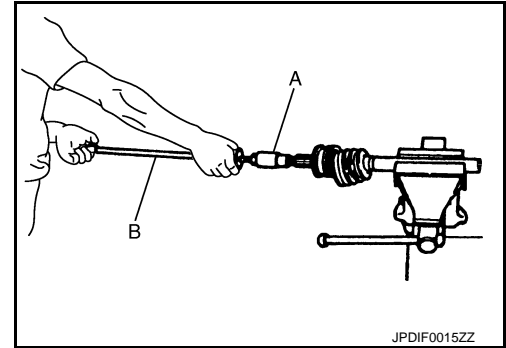

ASSEMBLY

Rear Final Drive Side

- If plug (1) has been removed, use a drift to press in a new one.

←: Press

A: Drift [SST: KV38100500 (-)]

B: Drift [SST: KV38102200 (-)]

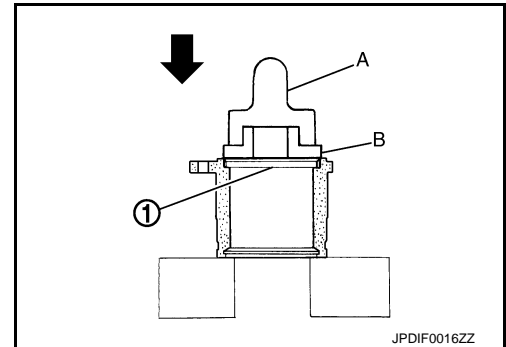

- Wrap serrated part of shaft with tape (A). Install boot band and boot to shaft. Be careful not to damage boot.

CAUTION:

Never reuse boot and boot band.

- Remove the tape wrapped around the serrated on shaft.

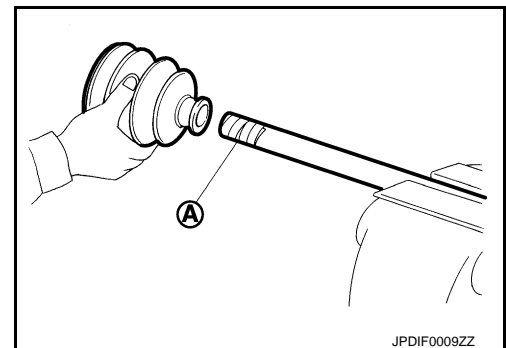

- Install ball cage/steel ball/inner race assembly (1) to shaft (2), and secure them tightly with a snap ring (3).

CAUTION:

Never reuse snap ring.

NOTE:

Align matching marks painted when ball cage/steel ball/inner race assembly were removed.

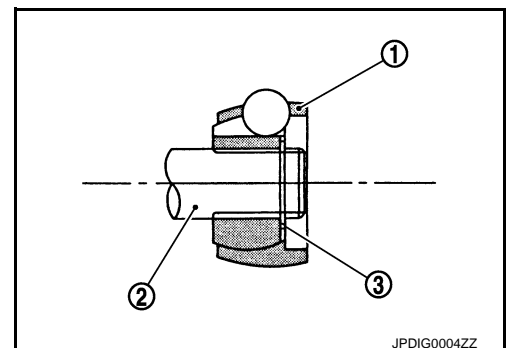

- Apply the appropriate amount of grease onto housing and slid surface.

NOTE:

REAR DRIVE SHAFT

< REMOVAL AND INSTALLATION >

Align matching marks painted when housing were removed.

Standard

Grease amount : Refer to [RAX-16, "Drive Shaft"](#).

6. Install stopper ring to housing.
7. After installed, pull shaft to check engagement between housing and stopper ring.
8. Install boot securely into grooves (indicated by "*" marks) shown in the figure.

CAUTION:

If grease adheres to the boot mounting surfaces (indicated by "*" marks) on shaft or housing, boot may be removed. Remove all grease from the surfaces.

9. To prevent the deformation of the boot, adjust the boot installation length (L) to the value shown below by inserting the suitable tool into the inside of boot from the large diameter side of boot and discharging inside air.

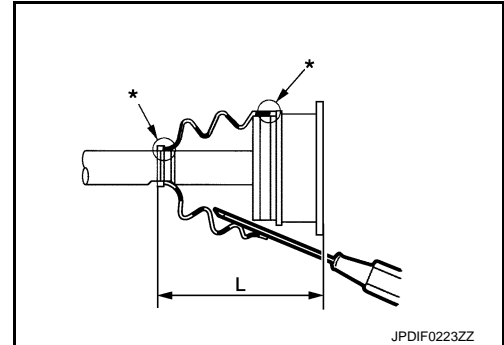

Standard

Boots installed length (L) : Refer to [RAX-16, "Drive Shaft"](#).

CAUTION:

- If the boot installation length is outside the standard, it may cause breakage of boot.
- Be careful not to touch the inside of the boot with the tip of tool.

10. Secure large and small ends of boot with new boot bands as shown in the figure.

CAUTION:

Never reuse boot band.

11. Secure housing and shaft, and then make sure that they are in the correct position when rotating boot. Install them with new boot band when the mounting positions become incorrect.

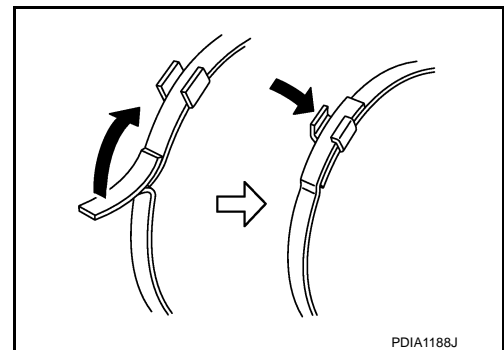

Wheel Side

1. Fill serration slot joint sub-assembly (1) with NISSAN genuine grease or equivalent until the serration slot and ball groove become full to the brim.

CAUTION:

After applying grease, use a shop cloth to wipe off old grease that has oozed out.

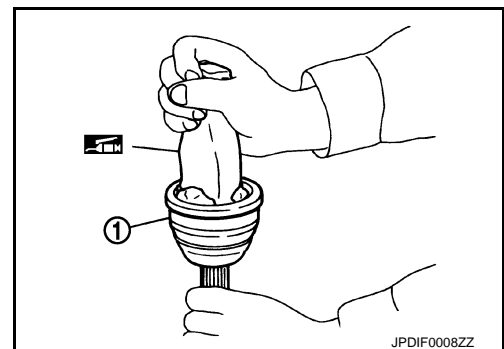

REAR DRIVE SHAFT

< REMOVAL AND INSTALLATION >

- Wrap serration on shaft with tape (A) to protect the boot from damage. Install boot and boot bands to shaft.

CAUTION:

Never reuse boot and boot band.

- Remove the tape wrapped around the serrated on shaft.
- Position circular clip on groove at the shaft edge.

CAUTION:

Never reuse circular clip.

NOTE:

Drive joint inserter is recommended when installing circular clip.

- Align both center axes of the shaft edge and joint sub-assembly. Then assemble shaft with circular clip joint sub-assembly.
- Install joint sub-assembly to shaft using plastic hammer.

CAUTION:

Confirm that joint sub-assembly is correctly engaged while rotating drive shaft.

- Apply the balance of the specified amount of grease into the boot inside from large diameter side of boot.

Standard

Grease amount : Refer to [RAX-16, "Drive Shaft"](#).

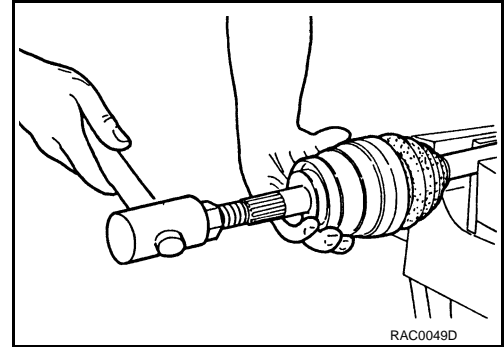
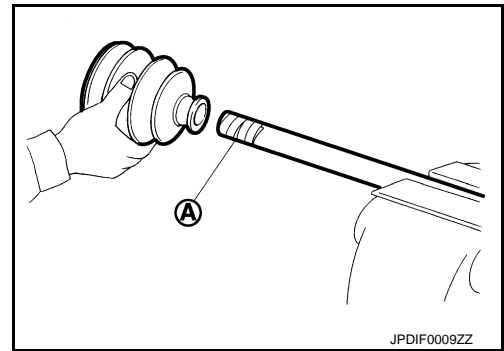

- Install the boot securely into grooves (indicated by "*" marks) shown in the figure.

CAUTION:

If grease adheres to the boot mounting surface (with "*" mark) on the shaft or housing, boot may come off. Remove all grease from the surfaces.

- To prevent the deformation of the boot, adjust the boot installation length (L) to the specified value shown below by inserting the suitable tool into inside of the boot from the large diameter side of boot and discharging the inside air.

Standard

Boots installed length (L) : Refer to [RAX-16, "Drive Shaft"](#).

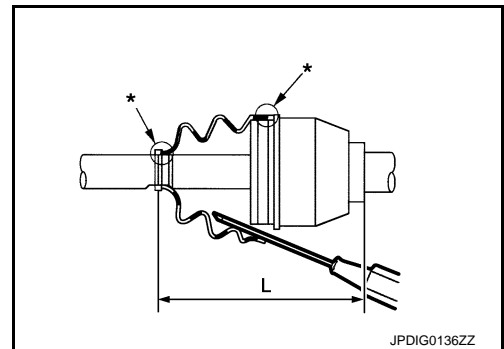

CAUTION:

- If the boot installation length is outside the standard, it may cause breakage of boot.
- Be careful not to touch the inside of the boot with the tip of tool.

- Secure the large and small ends of the boot with boot bands using the boot band crimping tool (A) [SST: KV40107300 (-)].

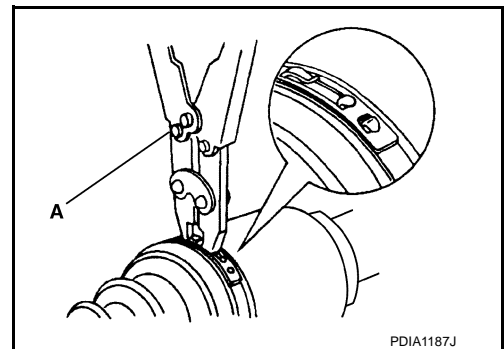

NOTE:

REAR DRIVE SHAFT

< REMOVAL AND INSTALLATION >

Secure boot band so that dimension (M) meets the specification as shown in the figure.

Dimension (M) : 2.0 – 3.0 mm (0.079 – 0.118 in)

11. Secure joint sub-assembly and shaft, and then make sure that they are in the correct position when rotating boot. Install them with boot band when boot installation positions become incorrect.
12. Install dust shield to drive shaft.

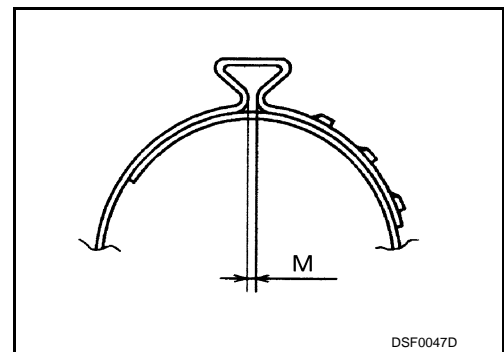

INFOID:000000001907767

Inspection

INSPECTION AFTER REMOVAL

- Move joint up/down, left/right, and in the axial direction. Check for any rough movement or significant looseness.
- Check boot for cracks or other damage, and also for grease leakage.
- If a malfunction is found, disassemble drive shaft, and then replace with new one.

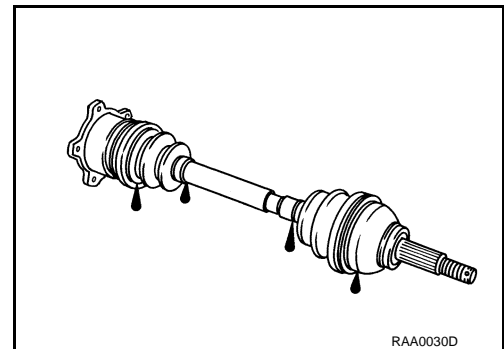

A

B

C

RAX

E

F

G

H

I

J

K

L

M

N

O

P

SERVICE DATA AND SPECIFICATIONS (SDS)

< SERVICE DATA AND SPECIFICATIONS (SDS)

SERVICE DATA AND SPECIFICATIONS (SDS)

SERVICE DATA AND SPECIFICATIONS (SDS)

Wheel Bearing

INFOID:000000001907768

Axial end play	0.05 mm (0.002 in) or less
----------------	----------------------------

Drive Shaft

INFOID:000000001907769

Joint	Wheel side	Final drive side
Grease quantity	110 – 120 g (3.88 – 4.23 oz)	124 – 134 g (4.37 – 4.73 oz)
Boots installed length	150.68 mm (5.93 in)	155 mm (6.10 in)